

SERIES 60

Dynapar™ brand

Heavy Duty Rotopulser®

Key Features

- Heavy-duty bearings with 1/2" diameter shaft
- LED optical light source
- Unbreakable disk
- Wide selection of resolutions available up to 2500 PPR
- Servo ring and face mount options



SPECIFICATIONS

ELECTRICAL

Power Requirements: 5 to 15 VDC max. 115 mA max. plus load requirements
Frequency Response: 50 kHz
Minimum Free Path: Between any A and B transition, will not be less than 12.5% of one full electrical cycle. This includes effects of jitter, phase and symmetry shifts.

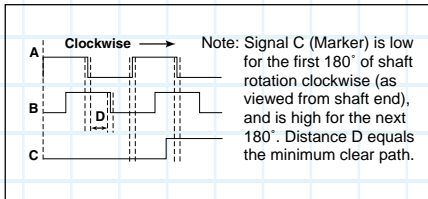

Differential Output: 7272, 40 mA sink/source; connections
 Mating Connector: Style MS3106A-18-1S; Dynapar Part No. MCN-N6
Single-Ended Output: 7272, 40 mA sink/source; Mating Connector: Style MS3106A-14S-6S; Dynapar Part No. MCN-N4

ELECTRICAL CONNECTIONS

Single-Ended Output (6-pin)		
Function (If Used)	MS Pin No.	#14002090010* Cable Accessory Color Code
Signal A	B	RED
Signal B	D	BLUE
Signal C (Marker)	A	GREEN
+V	E	WHITE
Common	C	BLACK
Shield	F	SHIELD

Differential Line Driver (10-pin)		
Function (If Used)	MS Pin No.	#14004190010* Cable Accessory Color Code
Signal A	B	RED
Signal \bar{A}	G	BLACK
Signal B	D	BLUE
Signal \bar{B}	H	BLACK
Signal C (Marker)	A	GREEN
Signal \bar{C}	I	BLACK
+V	E	WHITE
Common	C	BLACK
Shield	F	SHIELD
Not Used	J	

*This is a mating connector/cable assembly described in the Encoder Accessories section of this catalog. Color-coding information is provided here for reference.

MECHANICAL

Weight: 26 oz.
Speed Range: Up to 3600 RPM
Shaft Loading: Radial: 15 lbs. overhung; Axial: 5 lbs.
Inertia: 170 gm-cm²
Starting Torque: 0.45 oz-in (0.30 oz-in for 1/4 in. dia. shaft)
Running Torque: 0.35 oz-in (0.15 oz-in for 1/4 in. dia. shaft)
Shaft Diameters: 1/4", 1/2" (-0.0003"/-0.0007")

ENVIRONMENTAL

Enclosure Rating: NEMA 12 / IP54;
Temperature Range: 0-54°C

Ordering Information

To order, complete the model number with code numbers from the table below:

Code 1: Model	Code 2: Housing	Code 3: Shaft	Code 4: Output	Code 5: Voltage	Code 6: Pulses/Rev	Code 7: Wiring	Code 8: Misc
6 □	□	□	□	F	□ □ □ □	A	□
2 Bidirectional, Heavy Duty 3 Bidirectional with Marker, Heavy Duty	A Standard Housing for Single Shaft C Standard Housing for Double Shaft H Hand-Held Housing with Double Shaft and two 12" Circumference Measuring Wheels	A 1/2" Dia, 1.0" Len with Flat B 1/2" Dia, 1.0" Len without Flat C 1/2" Dia, 1.5" Len with Flat D 1/2" Dia, 1.5" Len without Flat Available when Code 2 = A or C: G 1/4" Dia, 1.0" Len without Flat H 1/4" Dia, 1.0" Len with Flat	E Single Ended Available when Code 2 = A or C: D Differential	F 5 to 15 VDC	0001 0150 0530 0002 0180 0550 0004 0192 0600 0005 0200 0625 0006 0203 0720 0010 0240 0750 0012 0250 0800 0015 0256 0805 0018 0300 0833 0020 0306 0900 0025 0315 1000 0040 0360 1024 0045 0375 1200 0050 0382 1270 0060 0384 1500 0064 0390 1800 0090 0400 2000 0096 0402 2160 0100 0430 2250 0120 0450 2400 0125 0500 2500 0127 0508 0128 0512	A MS Connector	0 No Shaft Seals Available when Code 3 = A, B, C, or D: B Shaft Seals

DIMENSIONS inches [mm]

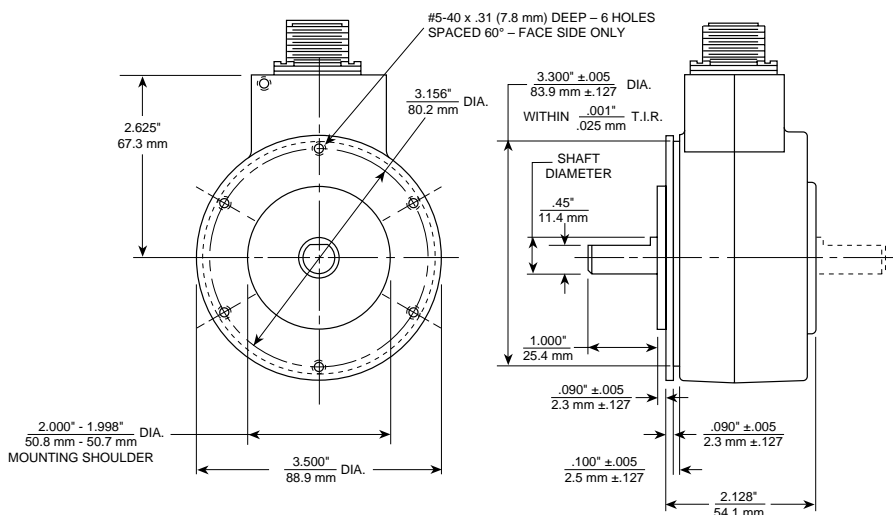

Hand-Held Speed Monitor



(Includes a Series 60 and dual 12" measuring wheels)

A Series 60H hand-held speed monitor is available as an accessory for web or roll calibration of steel, rubber, or paper continuous processes. These units are typically used as accessories for occasional calibration of a system speed, draw, or readout.

These hand-held monitors may be ordered with any PPR from the Series 60 code table. However, typical calibration applications with 12" measuring wheels use 60 PPR or 120 PPR, and provide excellent calibration resolution from zero up to full speeds. Refer to electrical connections 6-pin chart for pin-out functions of Series 62H.

Order Model No. 62H-AEF-___-AO.

Satellite Locations:

- **North America:** North Carolina, South Carolina, Connecticut, Massachusetts, New York, Canada, British Virgin Islands
- **West Indies:** St. Kitts • **Europe:** United Kingdom, Italy, France, Germany, Spain, Slovakia
- **South America:** Brazil • **Asia:** China, Japan, Korea, Singapore

Customer Service:

Tel.: +1.800.873.8731
 Fax: +1.847.662.4150
 custserv@dynapar.com

Technical Support

Tel.: +1.800.234.8731
 Fax: +1.847.782.5277
 northstar.techsupport@dynapar.com