

SERIES SL85

NorthStar™ brand

Bearingless Encoder

Key Features

- **Bearingless Design Mounts to 180 C-Face Motors**
- **Magneto-Resistive Technology Resists Dust, Dirt, Oil, Water, and Other Contaminants**
- **Dual-C-FFace Versions Available for “Sandwich” Mounting**
- **Single or Dual Isolated Outputs Available**



SPECIFICATIONS

STANDARD OPERATING CHARACTERISTICS

Code: Incremental
Pulses per Revolution: 64-2048
Phasing Sense: A leads B for Counter-Clockwise rotation (CCW) viewing encoder-mounted end
Quadrature Phasing: $90^\circ \pm 22^\circ$
Symmetry: $180^\circ \pm 54^\circ$
Index: 270°, ungated (optional gated to falling B edge)
Number of Output Modules: Single or Dual Redundant

ELECTRICAL

Input Power Requirements: 5-15 Volts DC, 45 mA typical per sensor module plus line driver load
Output Signals: Line Driver, 150mA source/sink
Frequency Response: 0 - 120kHz Data & Index
Electrical Immunity: 2kV ESD, Reverse Polarity, Short Circuit
Connector: 10 pin industrial duty latching, sealed NEMA 4 & 12, IP65

MECHANICAL

Max: Shaft Speed: 5,000 RPM
Mounting Configuration: 8.5" 180C face mount for NEMA MG1 standards
Housing Material: Cast Aluminum
Acceleration Rate: 3600 rpm/sec max
Shaft Length Required: 1.0" min
Allowable Shaft End-Play: $\pm 0.050"$
Allowable Shaft Runout: 0.003" TIR

ELECTRICAL CONNECTIONS

Signal	Connector Pin	Pigtail Cable	MS 3102E18-IT#
Common	1	Black	F
B	2	Green	B
A	3	Blue	A
Z *	4	Violet	C
No Connection	5	—	E
Vcc (5-15 VDC)	6	Red	D
B	7	Yellow	I
A	8	Gray	H
Z *	9	Orange	J
Shield	10	Braid	G

* Index (Z) optional. See Ordering Information

ENVIRONMENTAL

Operating Temperature Range:
 Standard: -40°C to +90°C
 Extended: -40°C to +100°C
Storage Temperature Range: -40°C to +120°C
Humidity: to 98% RH (non-condensing)
Shock (Sensor Module): 1 meter drop test, 30 G's Min
Vibration: 18 G's @ 5-2000 Hz spectrum

Ordering Information

To order, complete the model number with code numbers from the table below:

Code 1: Model	Code 2: PPR	Code 3: Index	Code 4: Wheel Bore	Code 5: Termination	Code 6: Electrical	Code 7: Cover/Adapter
<input type="checkbox"/> 8	<input type="checkbox"/> <input type="checkbox"/> <input type="checkbox"/> <input type="checkbox"/>	<input type="checkbox"/>	<input type="checkbox"/> <input type="checkbox"/> <input type="checkbox"/>	<input type="checkbox"/>	<input type="checkbox"/>	<input type="checkbox"/>
Ordering Information						
S8 Motor Mount Ring, for 8 1/2" C-Face Motors (180C) Single Output D8 Motor Mount Ring, for 8 1/2" C-Face Motors (180C) Dual Output	0064 0128 0256 0512 1024 2048	L No Index Available when Code 2 is 0512, 1024 or 2048 G Gated Index (Z, Z̄) Z Differential Index (Z, Z̄)	J04 5/8" bore J05 7/8" bore J06 1.00" bore J07 1-1/8" bore K09 1-3/8" bore K10 1-1/2" bore K11 1-5/8" bore K12 1-3/4" bore K13 1-7/8" bore K14 2.00" bore K15 2-1/8" bore K16 2-1/4" bore K17 2-3/8" bore K18 2-1/2" bore K19 2-7/8" bore Additional Shaft Sizes Available Up to 3.75" Maximum End of Shaft Mounting for GE & Emerson Motors N01 1.125" EOS N06 2.375" EOS N08 2.625" EOS N10 2.875" EOS	C Latching Industrial Connector with 1/2" NPT M 10 pin MS Connector Double C-face Sandwich Version D 1" Extended height connector E 3" extended height connector P 18" pigtail cable Q Latching Industrial Connector on 18" pigtail cable	L 5-15V in, 5-15V Line Driver (4428) out H Same as L with extended temp. to 100°C V 5-26V in, 5-26V Line Driver (IC-WE) out 5 5-15V in, 5V Line Driver (4428) out Differential, bidirectional signals (A, Ā, B, B̄)	C Standard Flat Cover E Extra heavy duty steel pie pan cover F Flat Thru-hole cover <div style="border: 1px solid black; padding: 5px; width: fit-content;"> Grounding brush kits available for End of Shaft Mounting, Consult Factory for ordering </div>

Note: See ACCESSORIES Section For Connectors, Spare Parts and Pulse Wheels

DIMENSIONS inch
[mm]

STANDARD HOUSING – SINGLE C-FACE

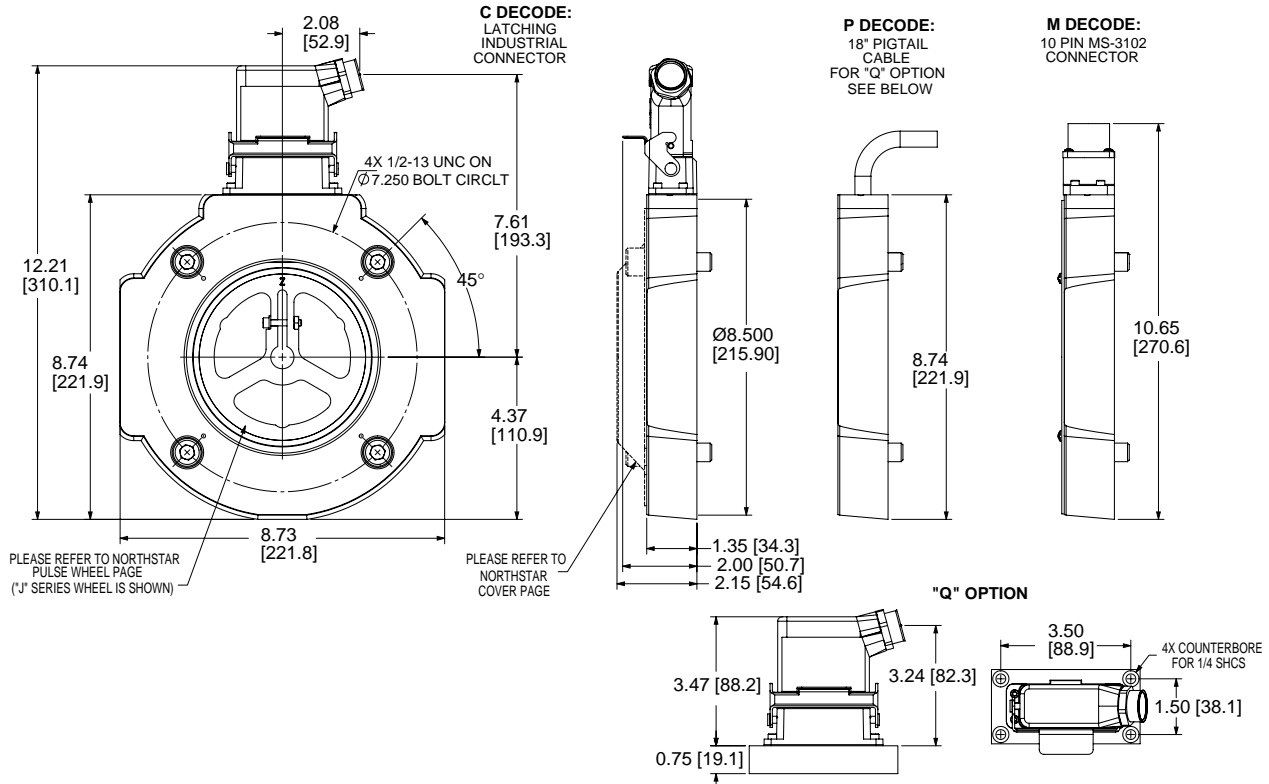

SERIES SL85



DIMENSIONS inch
 [mm]

DOUBLE C-FACE HOUSING

D-DECODE:
DOUBLE C-FACE
INDUSTRIAL
1" EXTENDED HEIGHT
LATCHING CONNECTOR

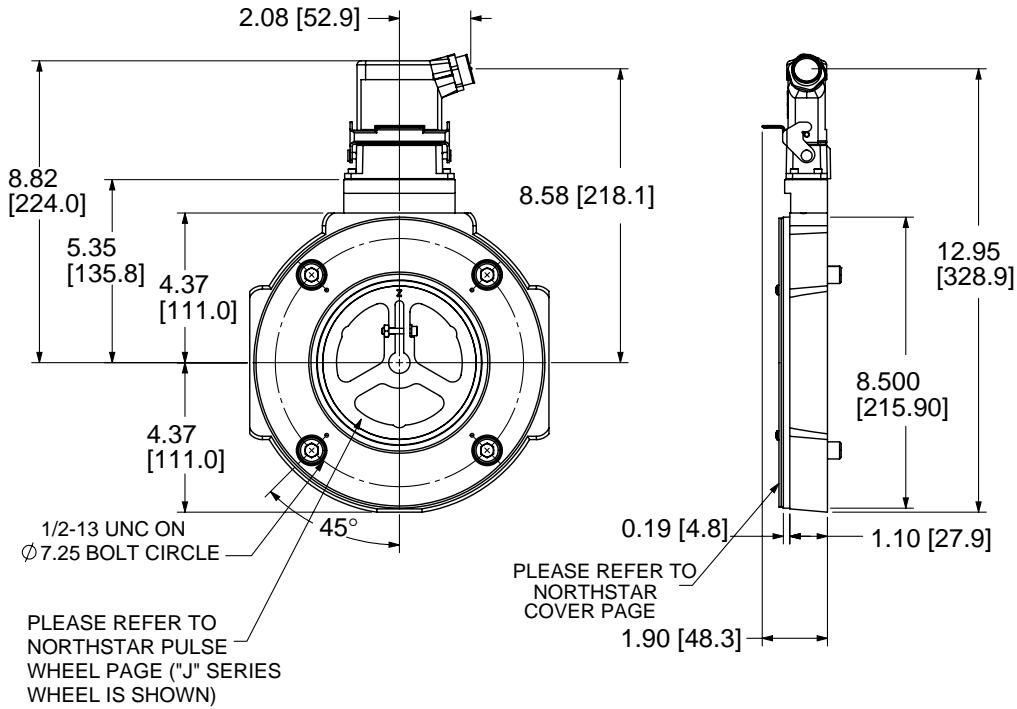

P-DECODE:
DOUBLE C-FACE
18" PIGTAIL
SEE "Q"
OPTION BELOW

E-DECODE:
DOUBLE C-FACE
3" EXTENDED HEIGHT
INDUSTRIAL
LATCHING CONNECTOR

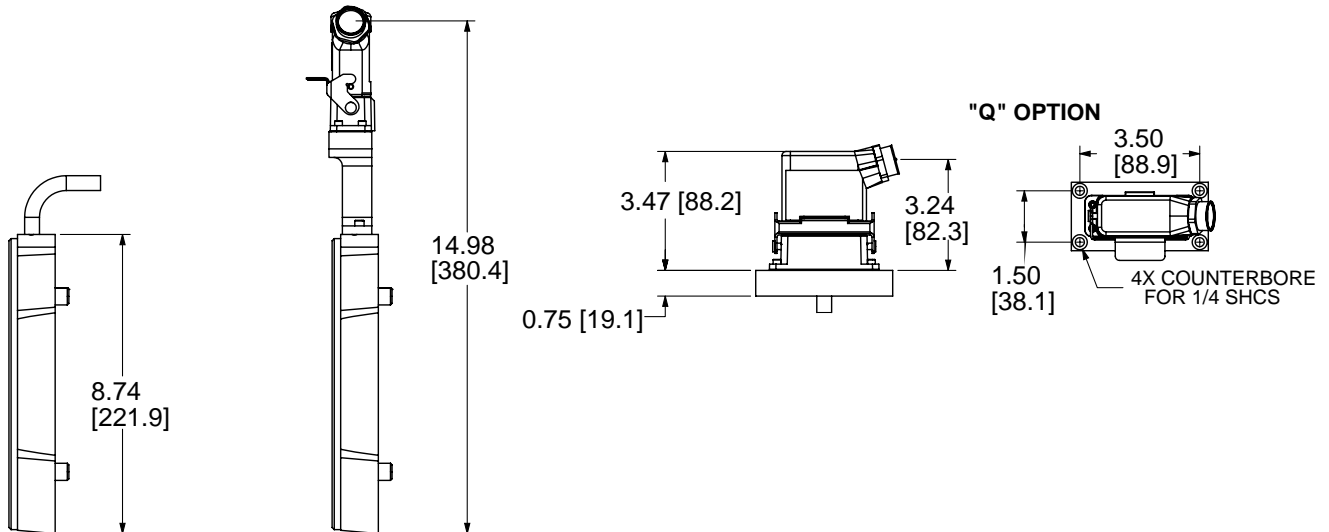

DIMENSIONS inch [mm]

DUAL OUTPUT HOUSING

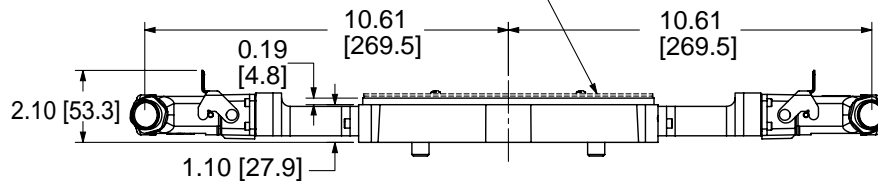
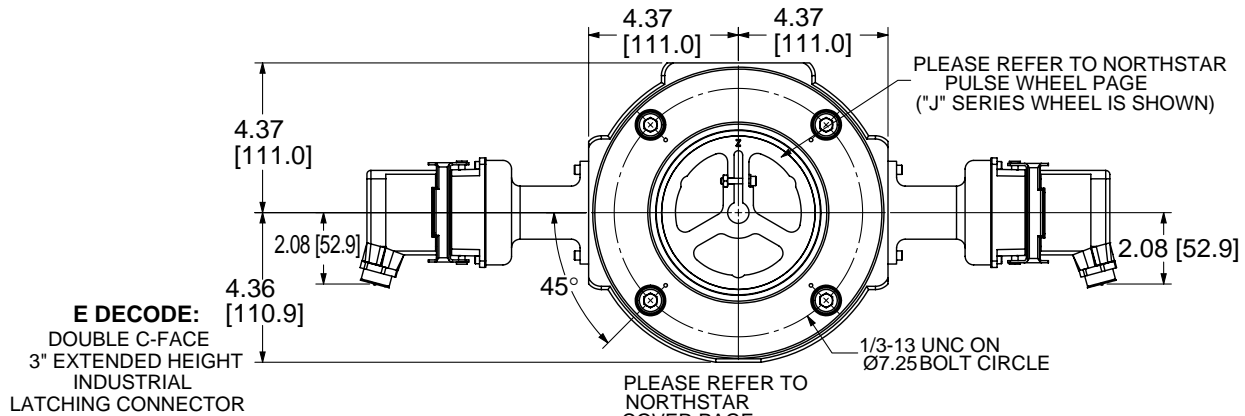

D DECODE:
DOUBLE C-FACE
1" EXTENDED HEIGHT
INDUSTRIAL
LATCHING CONNECTOR

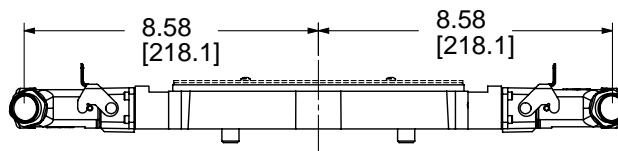

P DECODE:
DOUBLE C-FACE
18" PIGTAIL
SEE "Q" OPTION
AT RIGHT

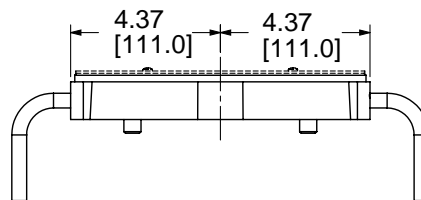

"Q" OPTION

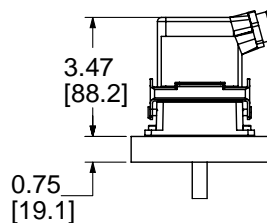
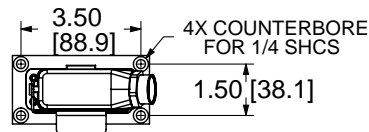

Worldwide Brands: NorthStar™ • Acuro™ • Dynapar™ • Hengstler™ • Harowe™

DYNAPAR™
INNOVATION - CUSTOMIZATION - DELIVERY

WWW.DYNAPAR.COM

Headquarters: 1675 Delany Road • Gurnee, IL 60031-1282 • USA

Customer Service:

Tel.: +1.800.873.8731

Fax: +1.847.662.4150

custserv@dynapar.com

Technical Support

Tel.: +1.800.234.8731

Fax: +1.847.662.4150

northstar.techsupport@dynapar.com

European Sales Representative

Hengstler GmbH

Uhlandstrasse 49, 78554 Aldingen

Germany

www.hengstler.com